

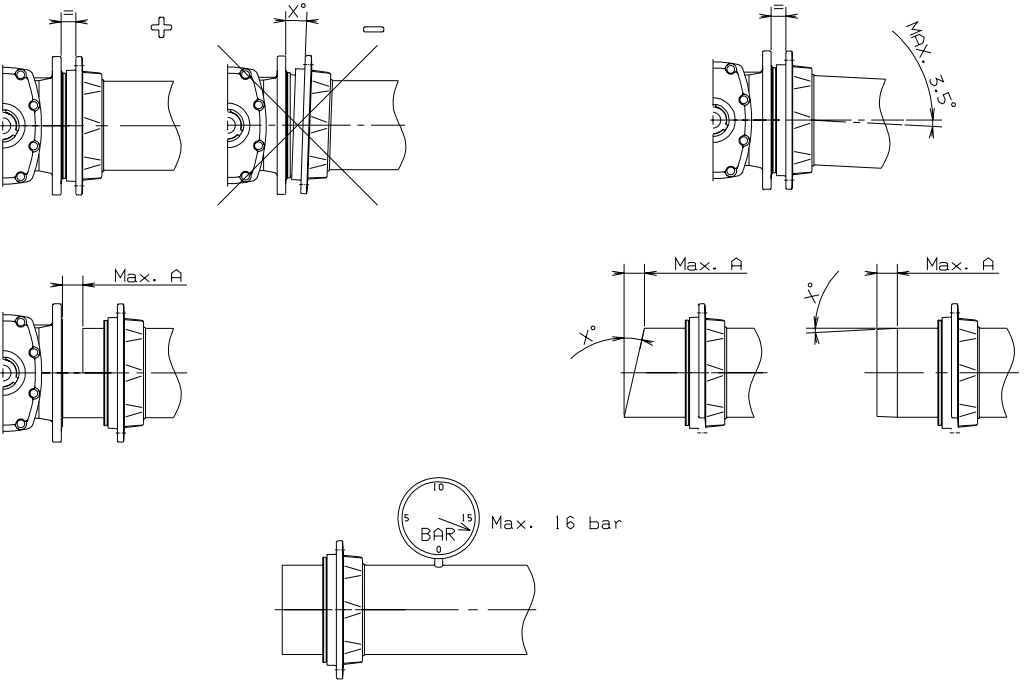

# 05-GG/GGG

## DN 50-200

Trækfast • Tensile restant •  
 Autobloquants •  
 Auto-blocante • Zugfest •  
 Strekkfast • Dragfast



DN/ext. dia	A	PN	Nm
50/66	25	10/16	75
60/77	25	10/16	75
65/82	25	10/16	75
80/98	30	10/16	75
100/118	30	10/16	75
125/144	40	10/16	75
150/170	40	10/16	150
200/222	50	10/16	150

